

Laboratori d'envol BHL5-33
 Flat area (m²) : 33.00
 Flat span (m) : 13.66
 Flat aspect ratio : 5.66
 Cells number : 39
 Version: 20211114

1-1 PLANFORM AND VAULT

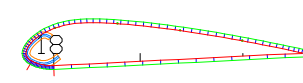
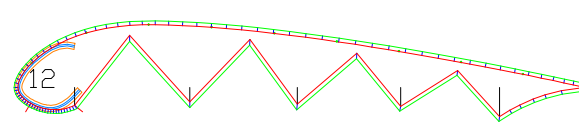
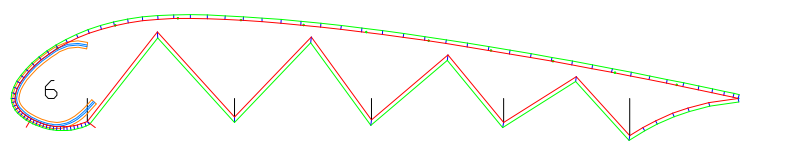
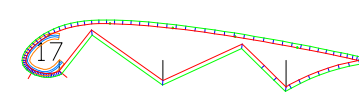
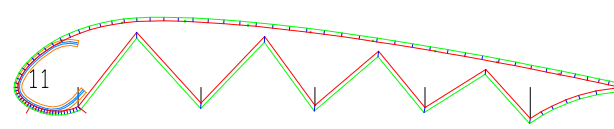
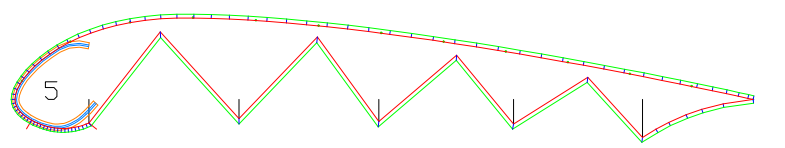
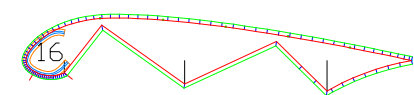
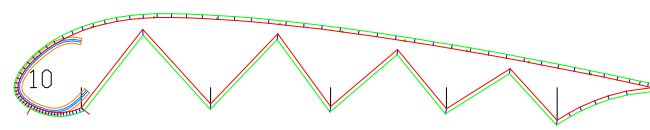
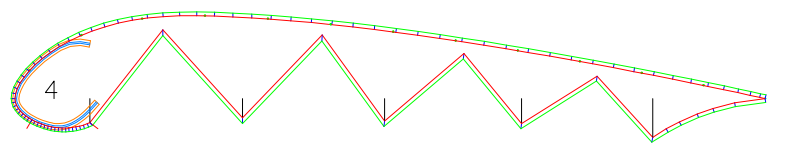
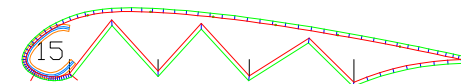
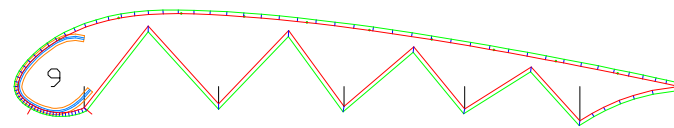
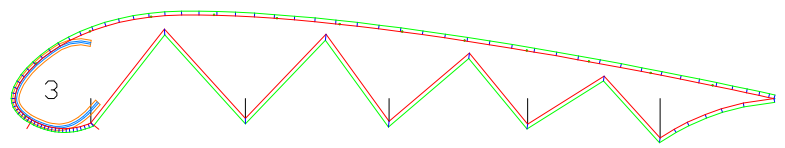
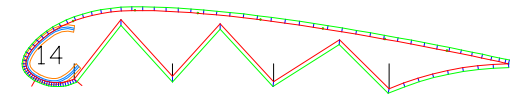
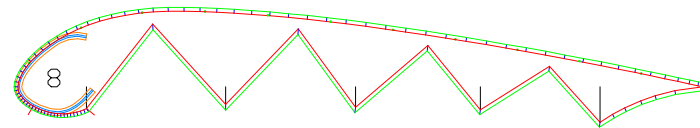
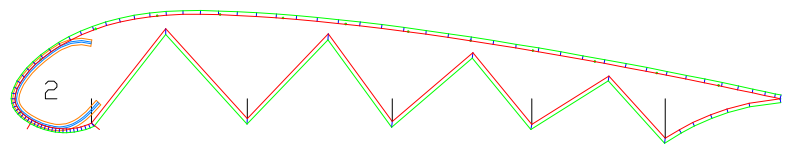
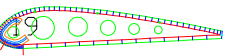
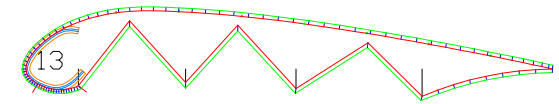
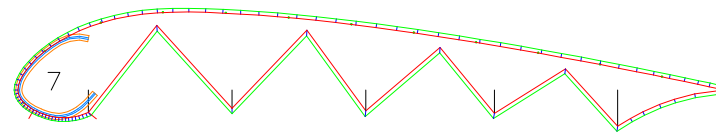
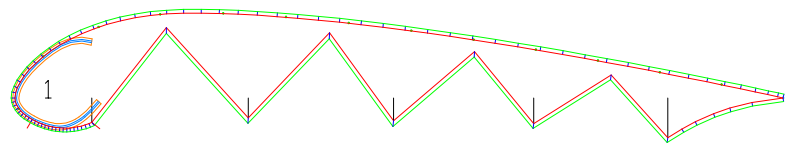

1-2 RIBS

Leading edge

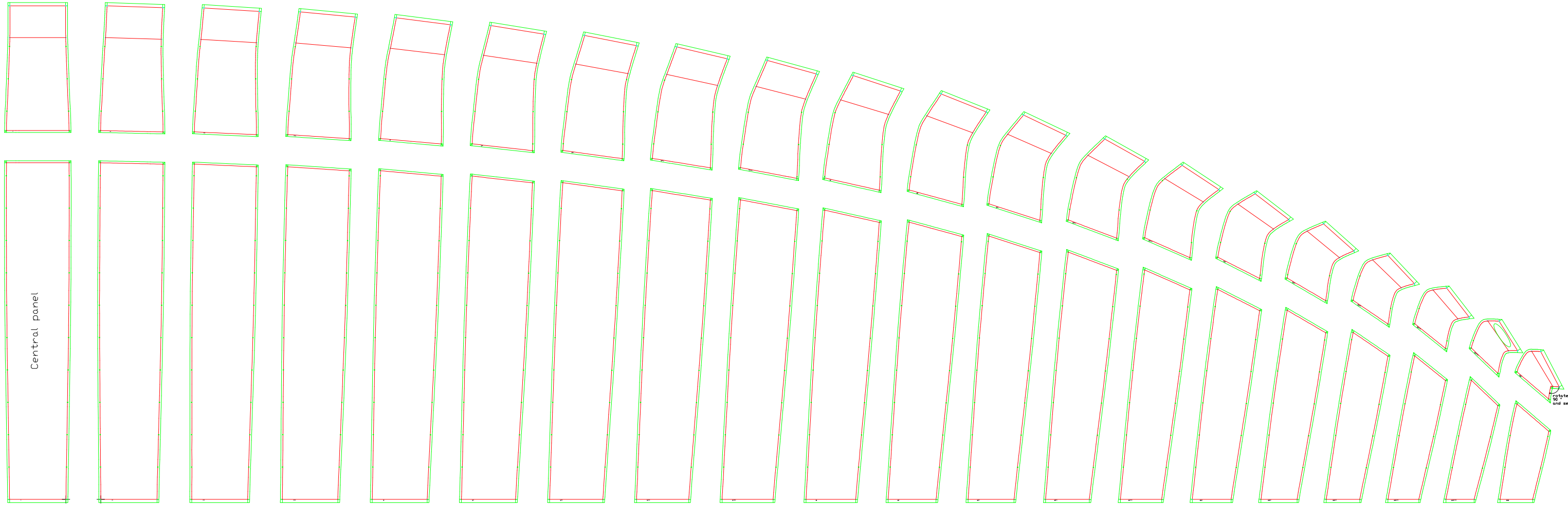

Trailing edge

1-3 EXTRADOS PANELS

Trailing edge

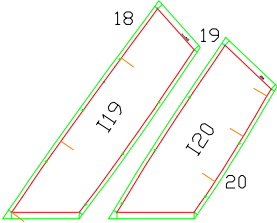

Leading edge

2-3 INTRADOS PANELS

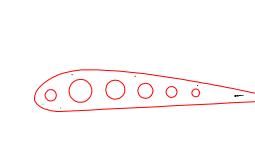
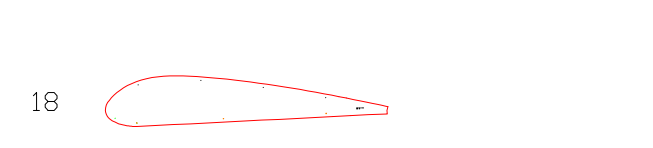
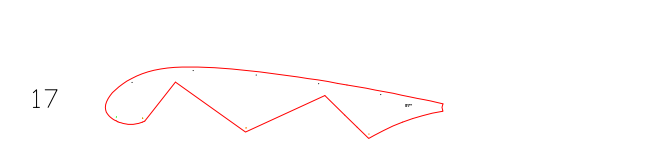
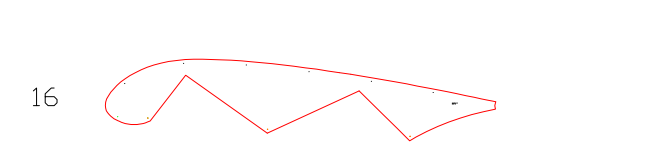
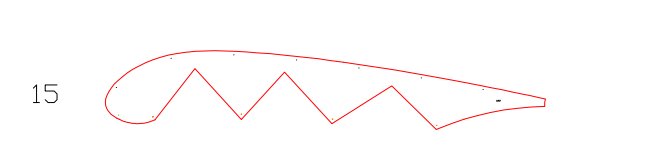
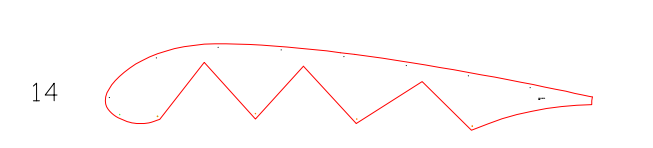
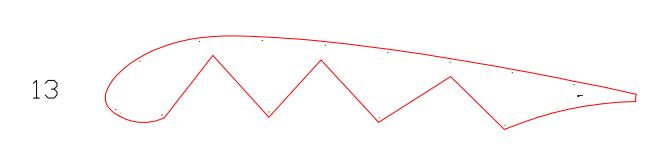
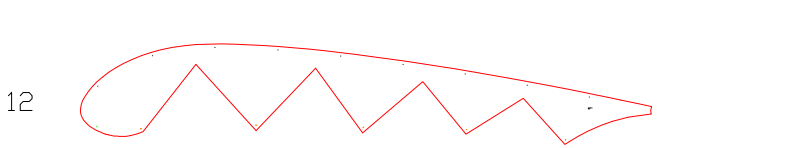
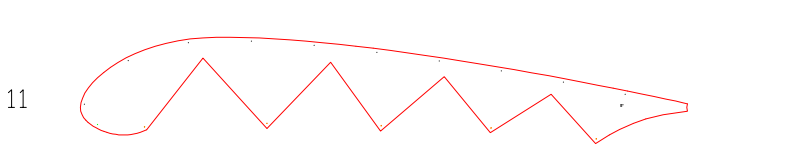
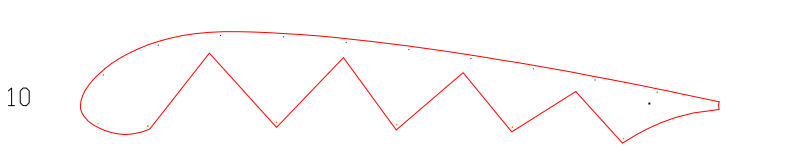
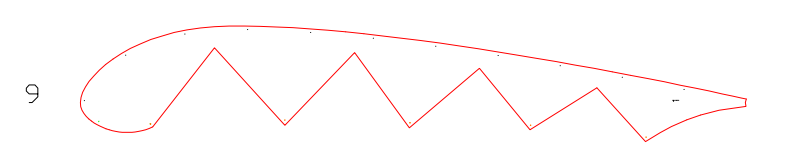
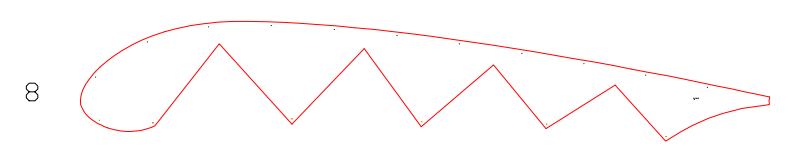
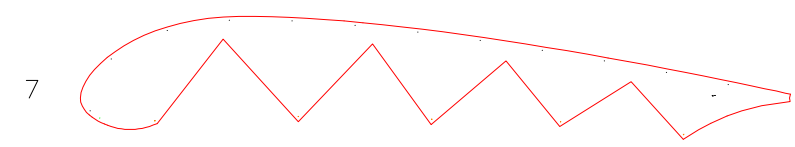
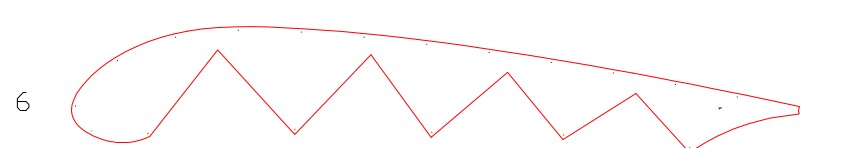
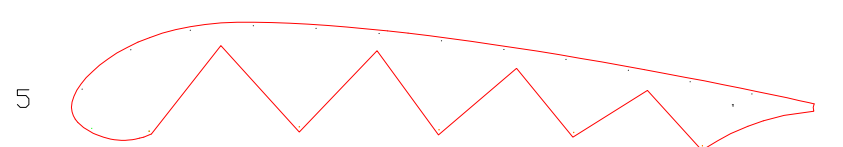
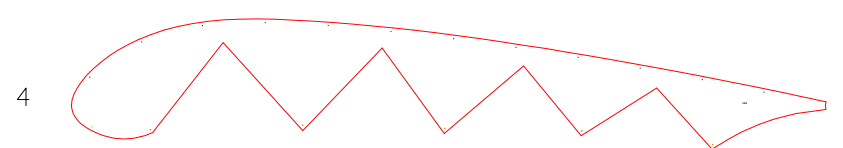
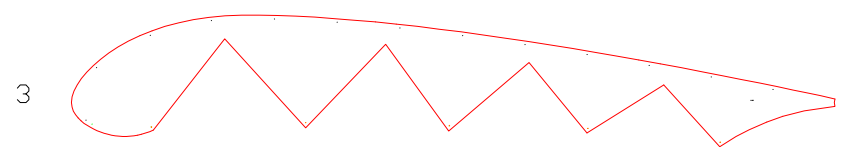
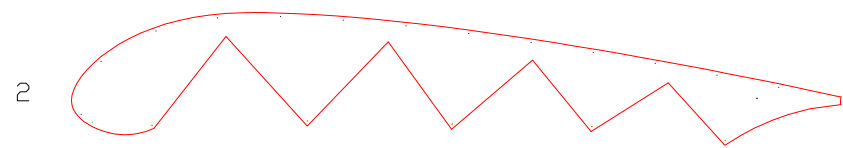
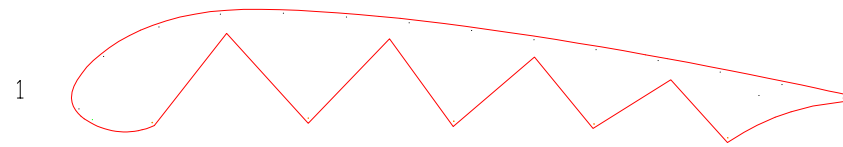

1-4 RIBS (FOR CUTTING TABLE)

Leading edge

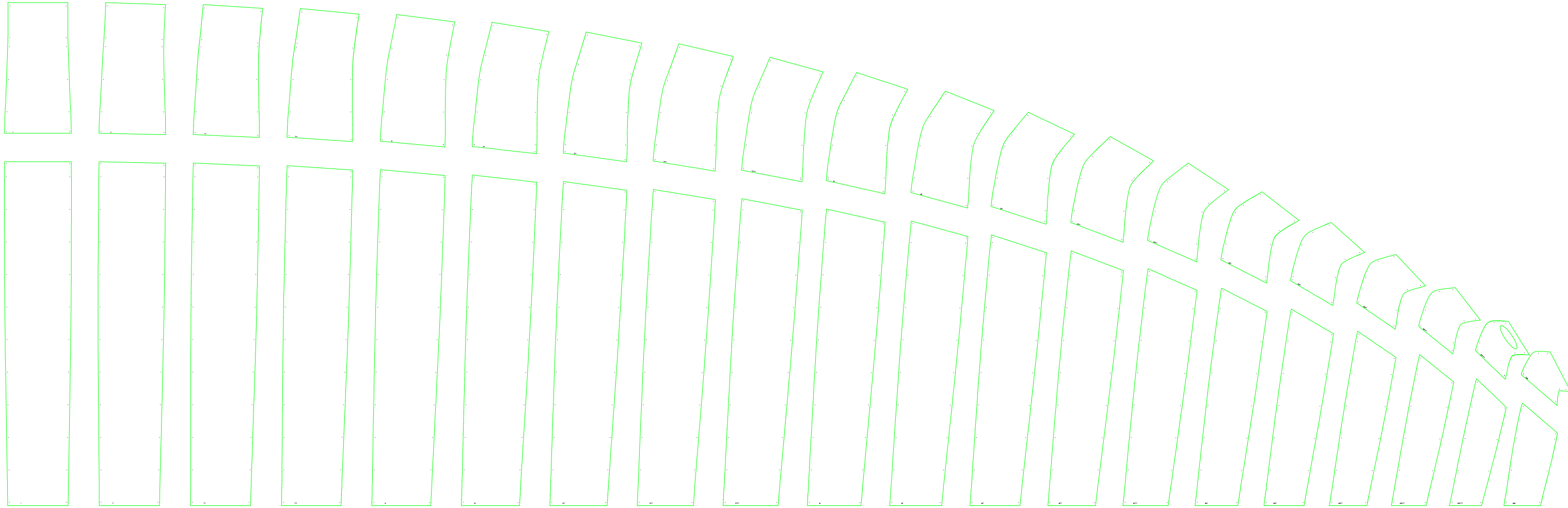

Trailing edge

1-5 EXTRADOS PANELS (FOR CUTTING TABLE)

Trailing edge

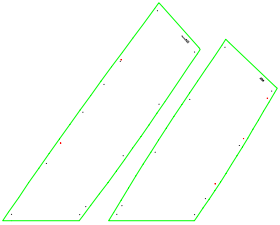

Leading edge

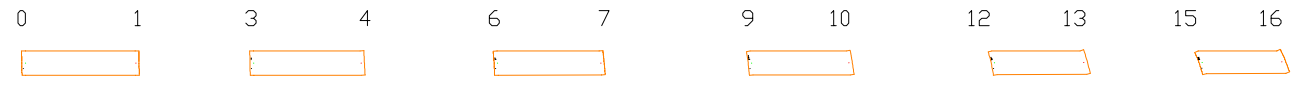



List of nylon rods (bloc 1)

Group 1		
Jonc 1		83.8
Jonc 2		83.4
Jonc 3		82.8
Jonc 4		81.8
Jonc 5		80.5
Jonc 6		78.9
Jonc 7		76.9
Jonc 8		74.7
Jonc 9		72.1
Jonc 10		69.2
Jonc 11		65.7
Jonc 12		61.8
Jonc 13		57.4
Jonc 14		52.6
Jonc 15		47.5
Jonc 16		42.1
Jonc 17		36.3
Group 2		
Jonc 18		29.9
Jonc 19		23.7
Jonc 20		0.0

calage= 33.00
 center pressure= 40.00
 glide ratio= 8.00
 glide angle= 7.13
 angle of attack= 5.66
 assiette= 1.47

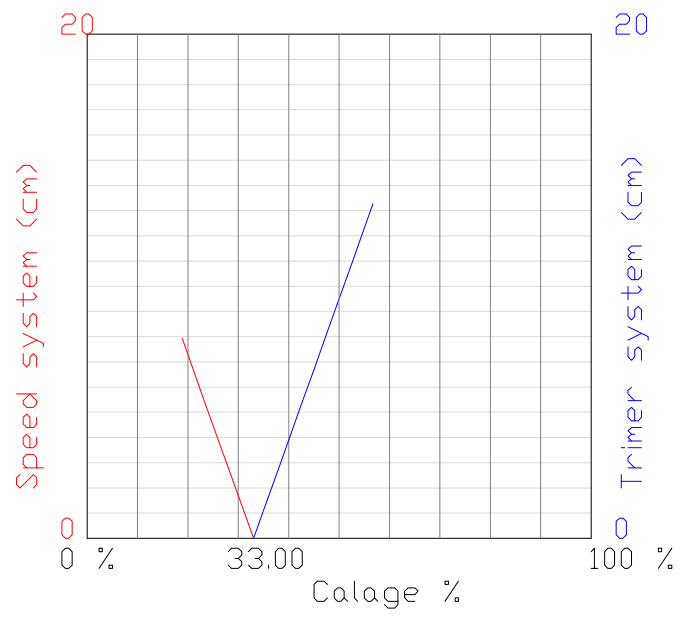
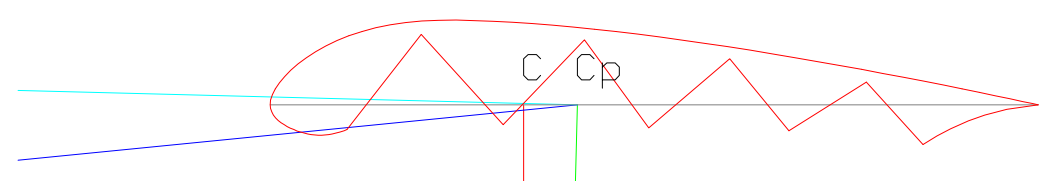

2-1 CALAGE ESTIMATION

pilot

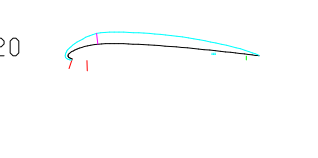
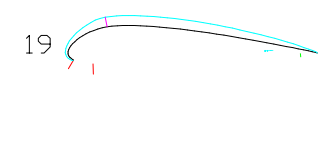
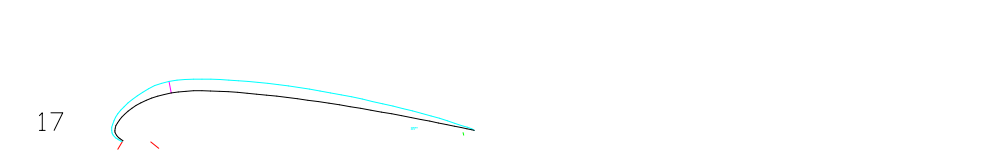
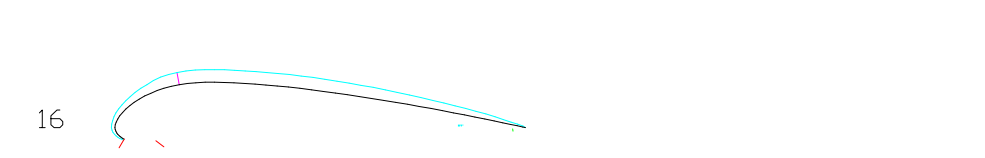
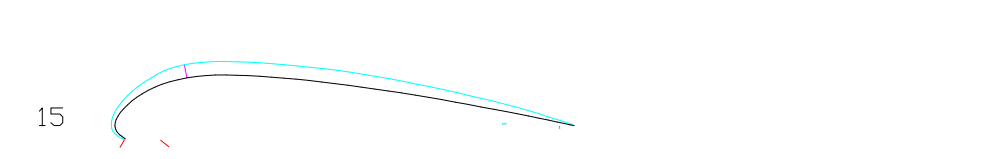
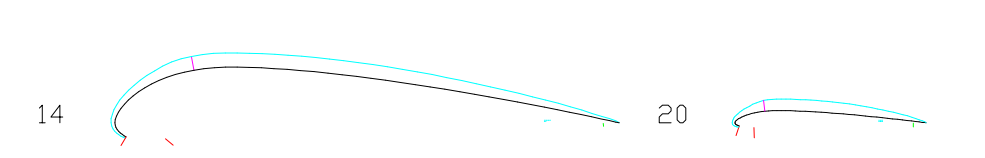
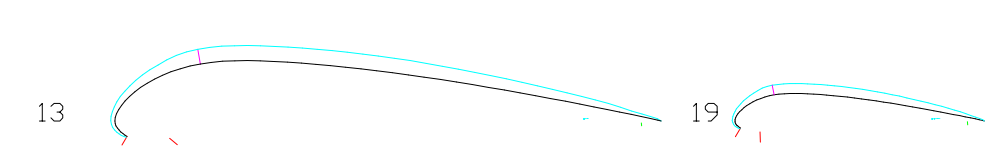
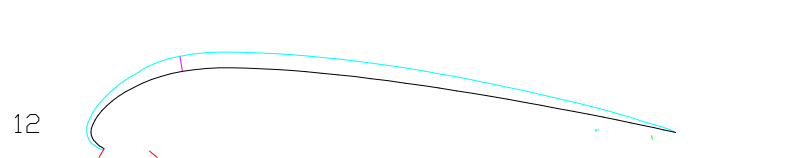
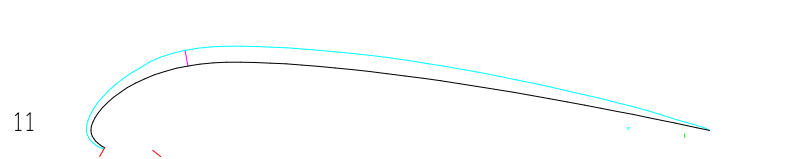
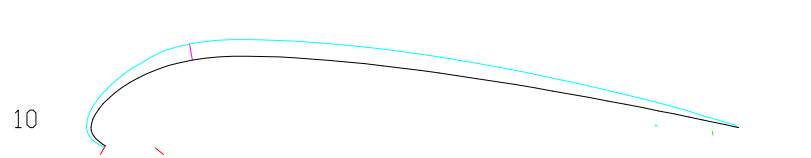
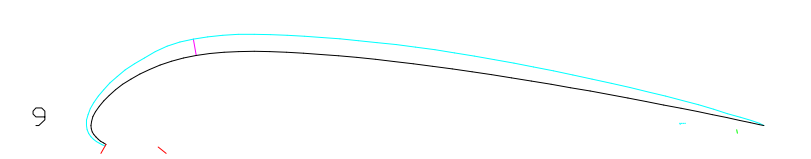
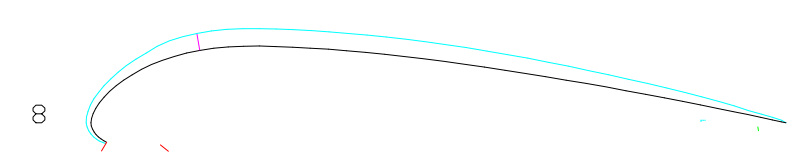
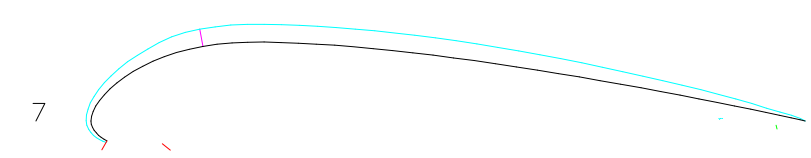
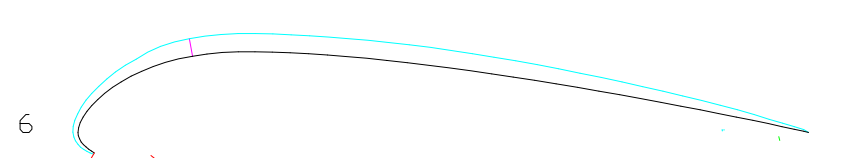
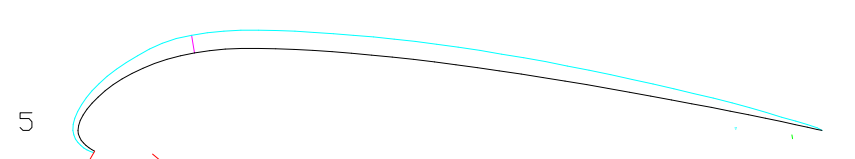
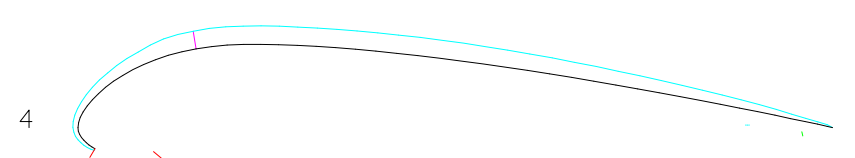
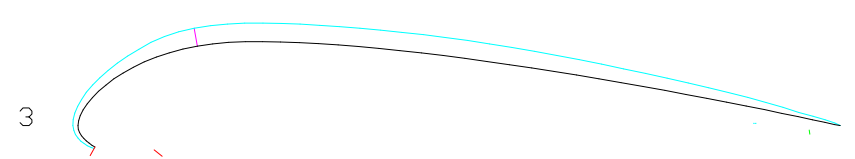
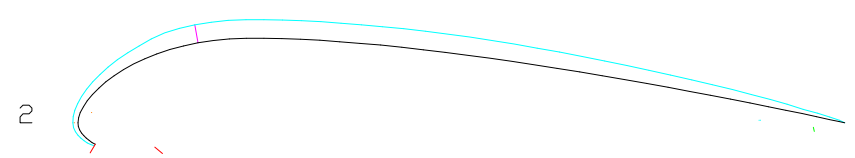
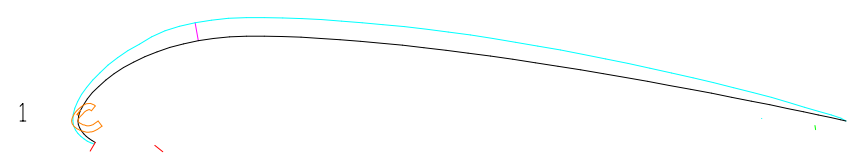

1-8 MIDDLE AND MIDDLE OVALIZED AIRFOILS

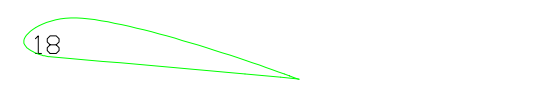
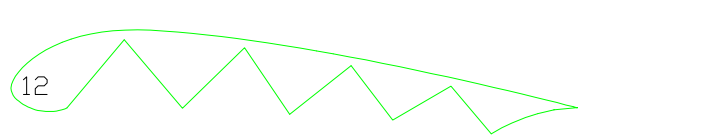
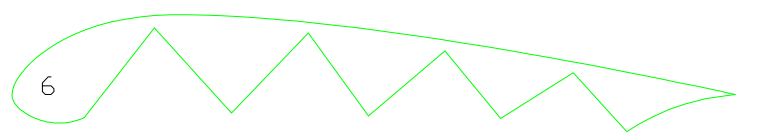
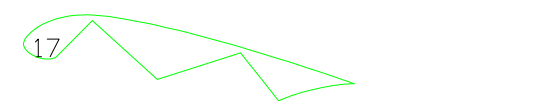
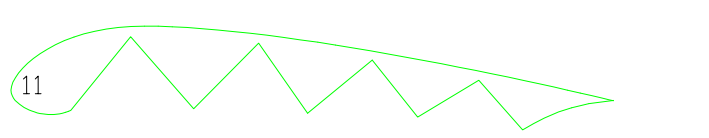
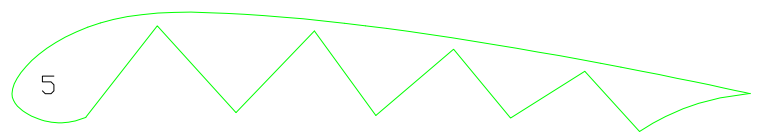
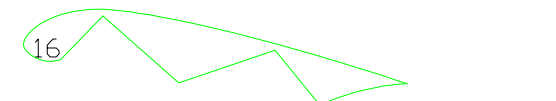
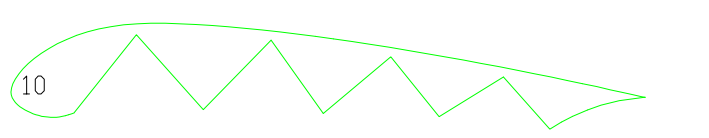
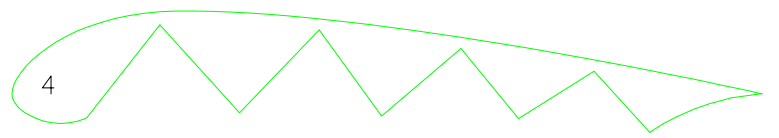
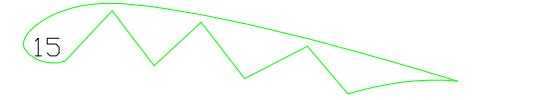
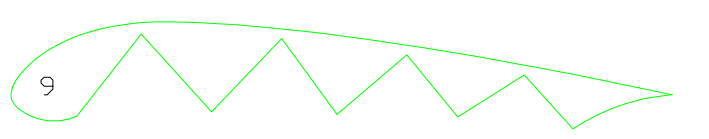
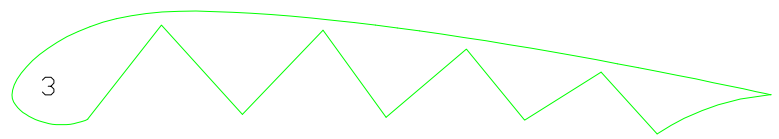
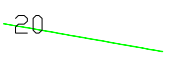
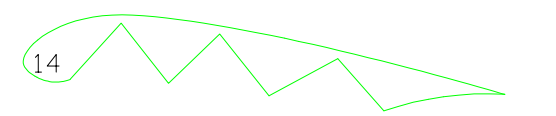
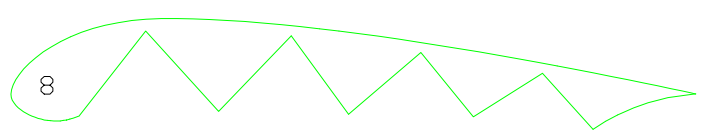
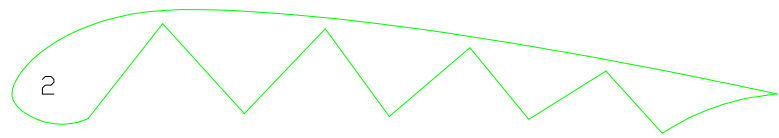
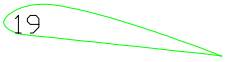
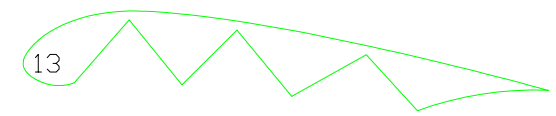
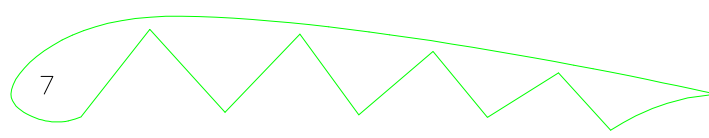
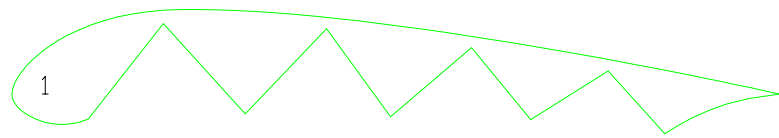

2-2 RIBS WASHIN ANGLE

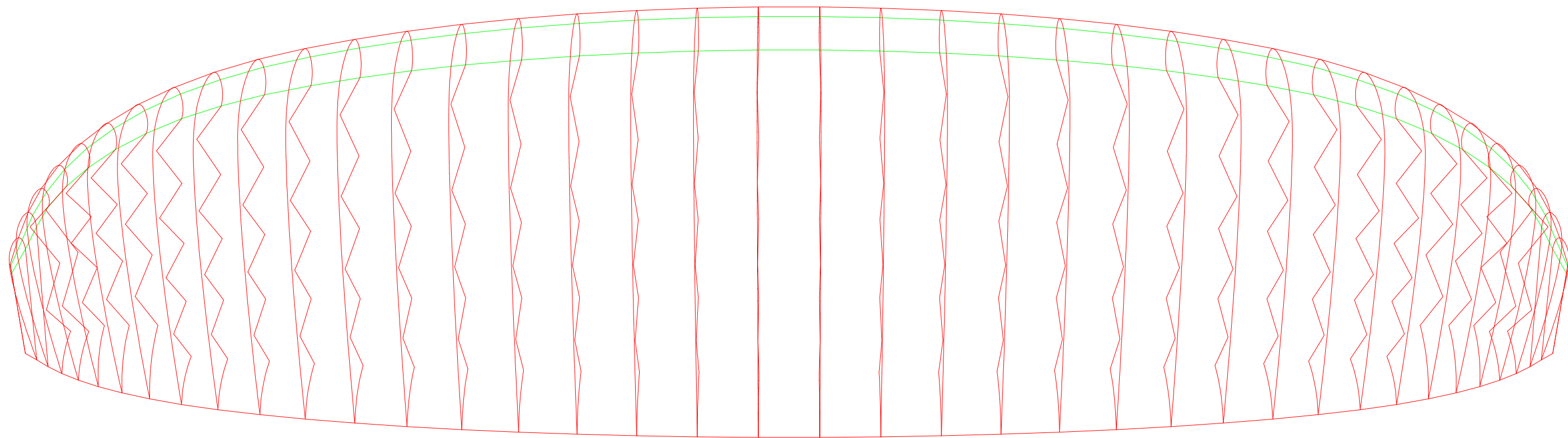

3-1 UPPER VIEW

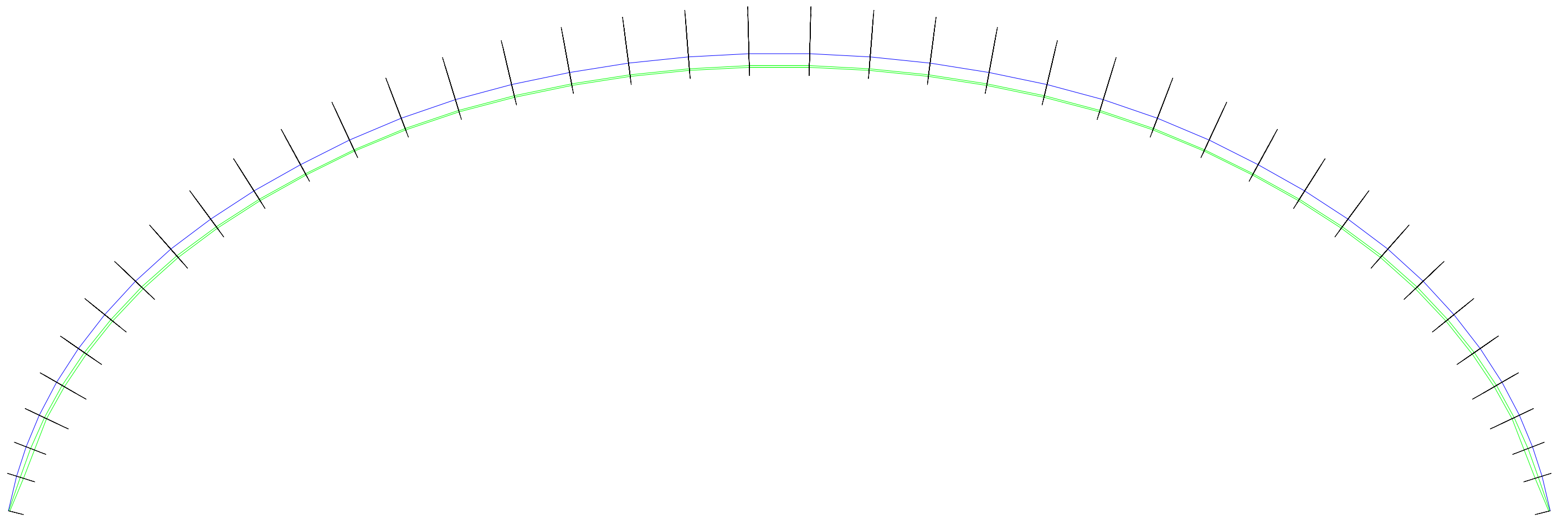

4-1 VAULT VIEW

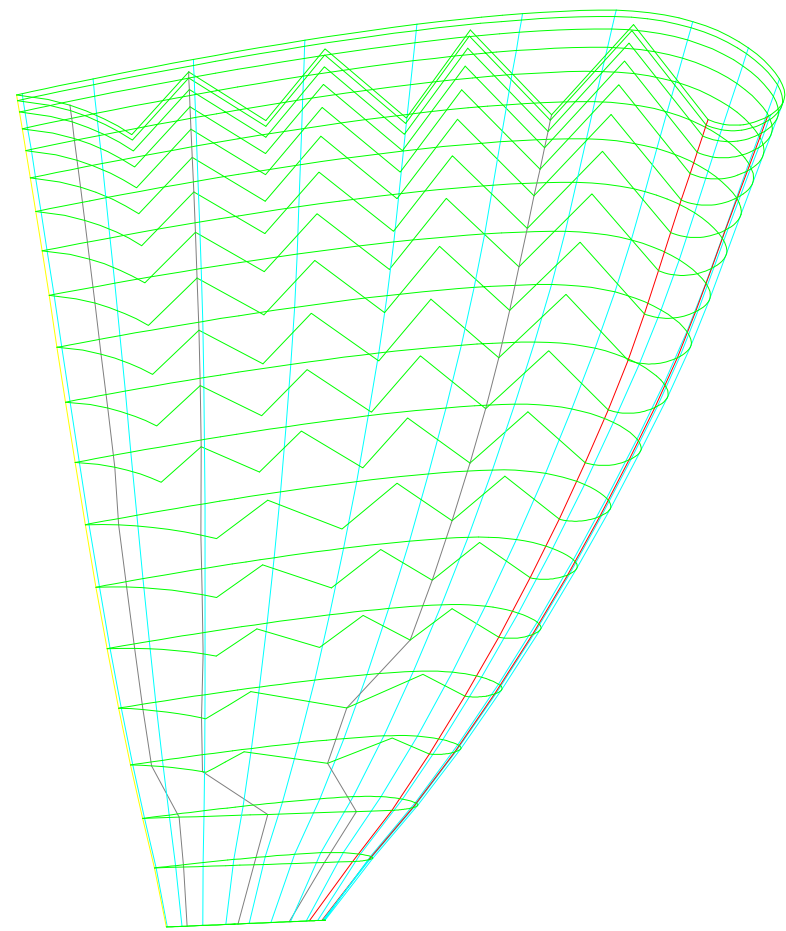

4-2 LATERAL VIEW

Line - Label - Length

1	1A1	47.0
2	2A1	472.5
3	2A2	459.6
4	2A3	429.7
5	3A1	178.8
6	3A2	178.8
7	3A4	178.8
8	3A5	178.8
9	3A6	178.9
10	3A7	178.9
11	4A1	143.1
12	4A2	130.9
13	4A3	129.8
14	4A4	128.2
15	4A5	126.5
16	4A6	135.7
17	4A7	142.5
18	4A8	131.4
19	4A9	129.3
20	4A10	126.1
21	4A11	122.7
22	4A12	127.6
23	4A13	145.3
24	4A14	134.0
25	4A15	128.4
26	4A16	120.6
27	4A17	113.5
28	4A18	110.9



Line - Label - Length

29	1B1	47.0
30	2B1	511.5
31	2B2	493.6
32	2B3	448.7
33	2B4	514.9
34	3B1	178.8
35	3B2	178.8
36	3B3	178.8
37	3B4	178.8
38	3B5	178.9
39	3B6	178.9
40	3A20	181.5
41	3B20	180.4
42	3C20	181.3
43	3D20	184.1
44	4B1	105.0
45	4B2	91.6
46	4B3	90.5
47	4B4	89.0
48	4B5	87.5
49	4B6	98.4
50	4B7	109.5
51	4B8	97.8
52	4B9	95.9
53	4B10	92.5
54	4B11	89.1
55	4B12	95.0
56	4B13	125.0
57	4B14	113.5
58	4B15	107.6
59	4B16	94.5
60	4B17	88.7
61	4B18	91.1

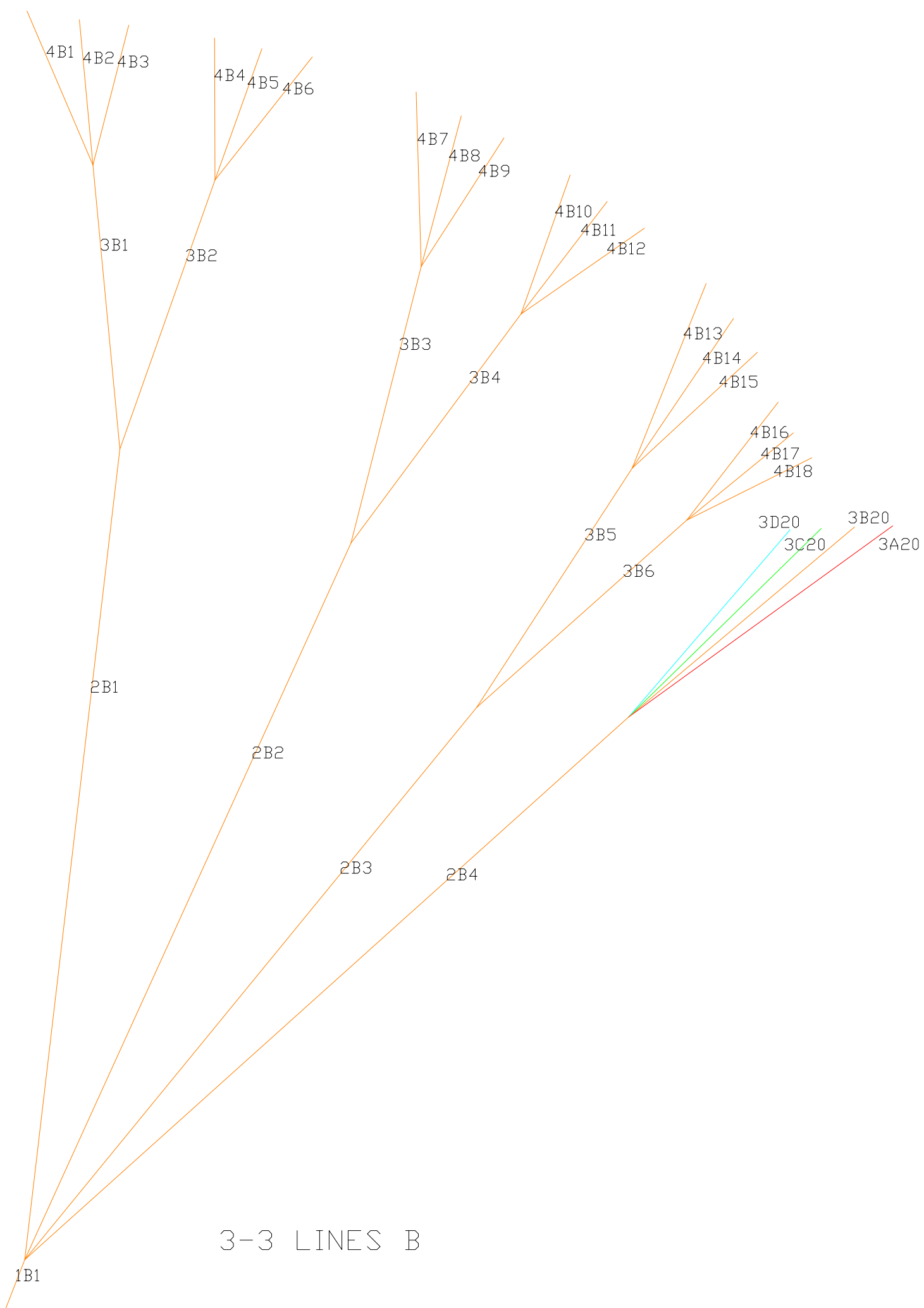

Line - Label - Length

62	1C1	47.0
63	2C1	508.8
64	2C2	490.8
65	2C3	448.8
66	3C1	178.9
67	3C2	178.9
68	3C4	178.9
69	3C5	178.9
70	3C6	178.9
71	3D7	179.0
72	3C8	178.9
73	4C1	108.4
74	4C2	95.1
75	4C3	94.0
76	4C4	92.6
77	4C5	91.1
78	4C6	101.9
79	4C7	113.1
80	4C8	101.6
81	4C9	99.8
82	4C10	96.1
83	4C11	92.5
84	4C12	97.3
85	4C13	122.4
86	4C14	111.4
87	4C15	105.9
88	4D13	123.4
89	4D14	112.0
90	4D15	106.0
91	4C16	95.2
92	4C17	88.7
93	4C18	94.2

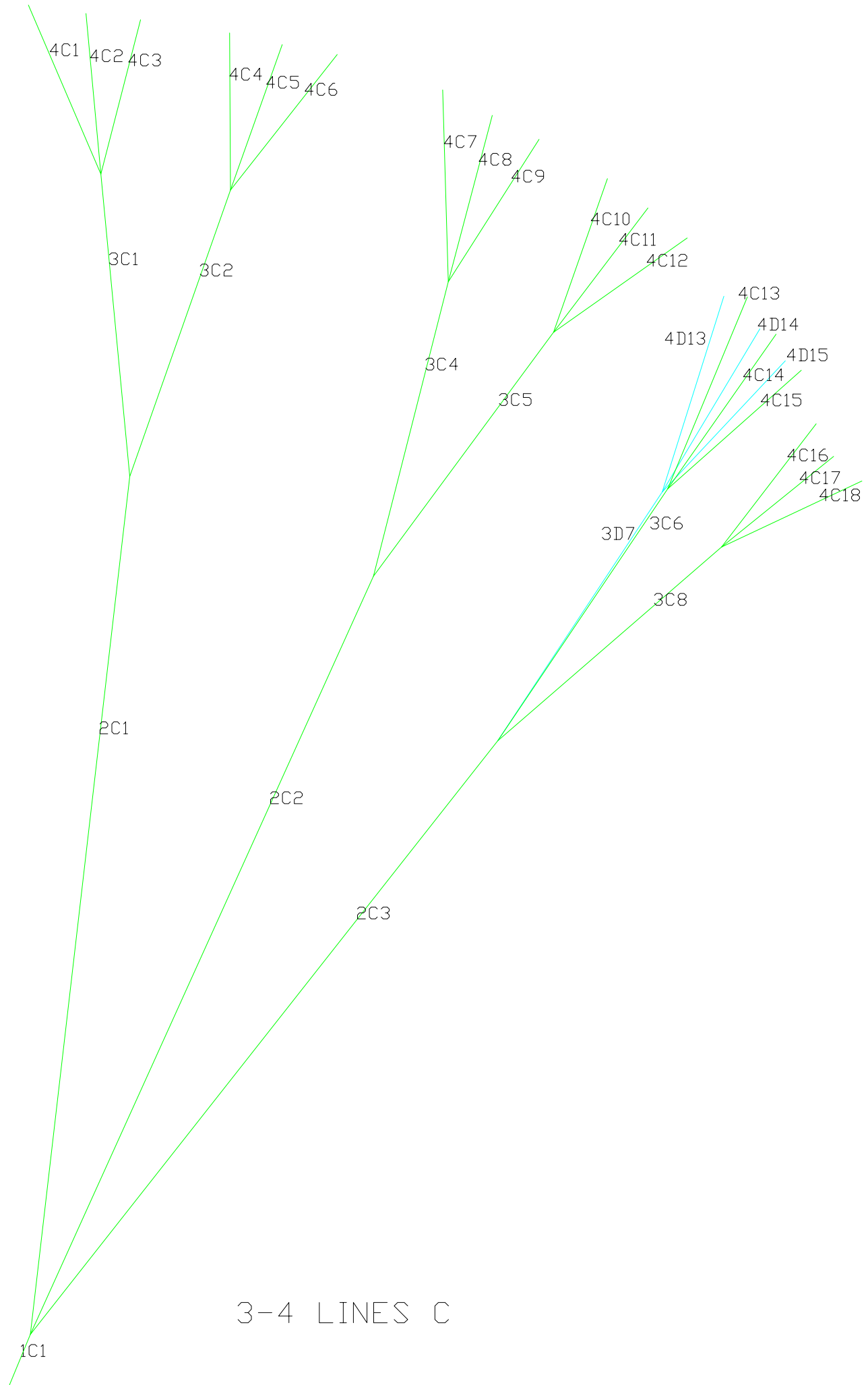

Line - Label - Length

94	1D1	47.0
95	2D1	503.8
96	2D2	488.8
97	3E1	178.9
98	3E2	178.9
99	3E3	178.9
100	3E4	178.9
101	4D1	115.7
102	4D2	103.0
103	4D3	102.2
104	4E1	124.5
105	4E2	112.4
106	4E3	111.5
107	4D4	101.1
108	4D5	99.8
109	4D6	110.4
110	4E4	110.4
111	4E5	108.8
112	4E6	118.3
113	4D7	119.1
114	4D8	108.1
115	4D9	106.5
116	4E7	126.9
117	4E8	115.9
118	4E9	113.7
119	4D10	102.7
120	4D11	98.8
121	4D12	102.6
122	4E10	109.5
123	4E11	104.7
124	4E12	107.1

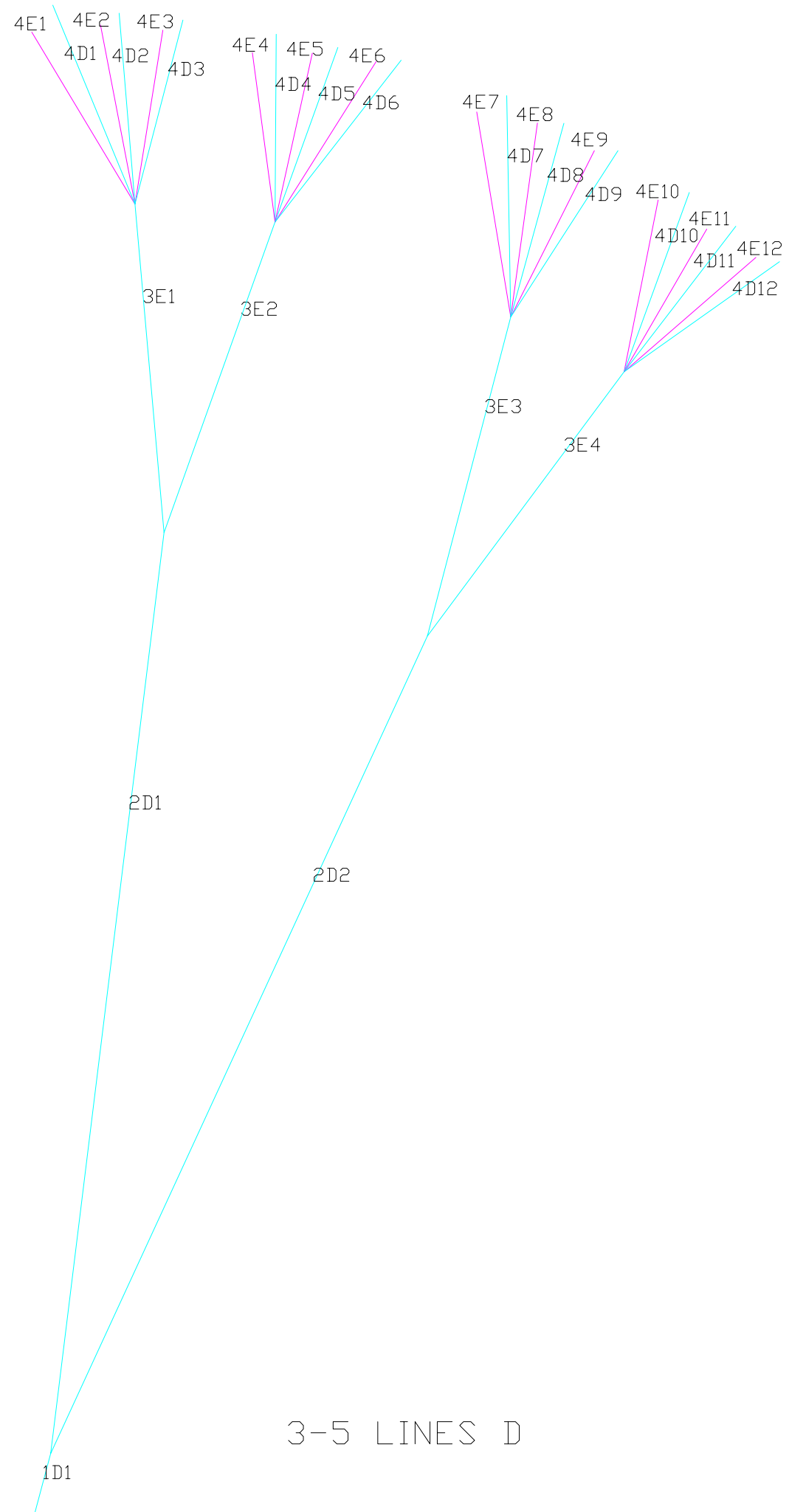

Line - Label - Length

125	1F1	275.0
126	2F1	352.0
127	2F2	318.0
128	2F3	280.0
129	3F2	222.3
130	3F4	195.1
131	3F6	194.6
132	3F8	214.2
133	3F10	196.0
134	3F12	193.5
135	3F14	215.4
136	3F16	194.6
137	3F19	188.0

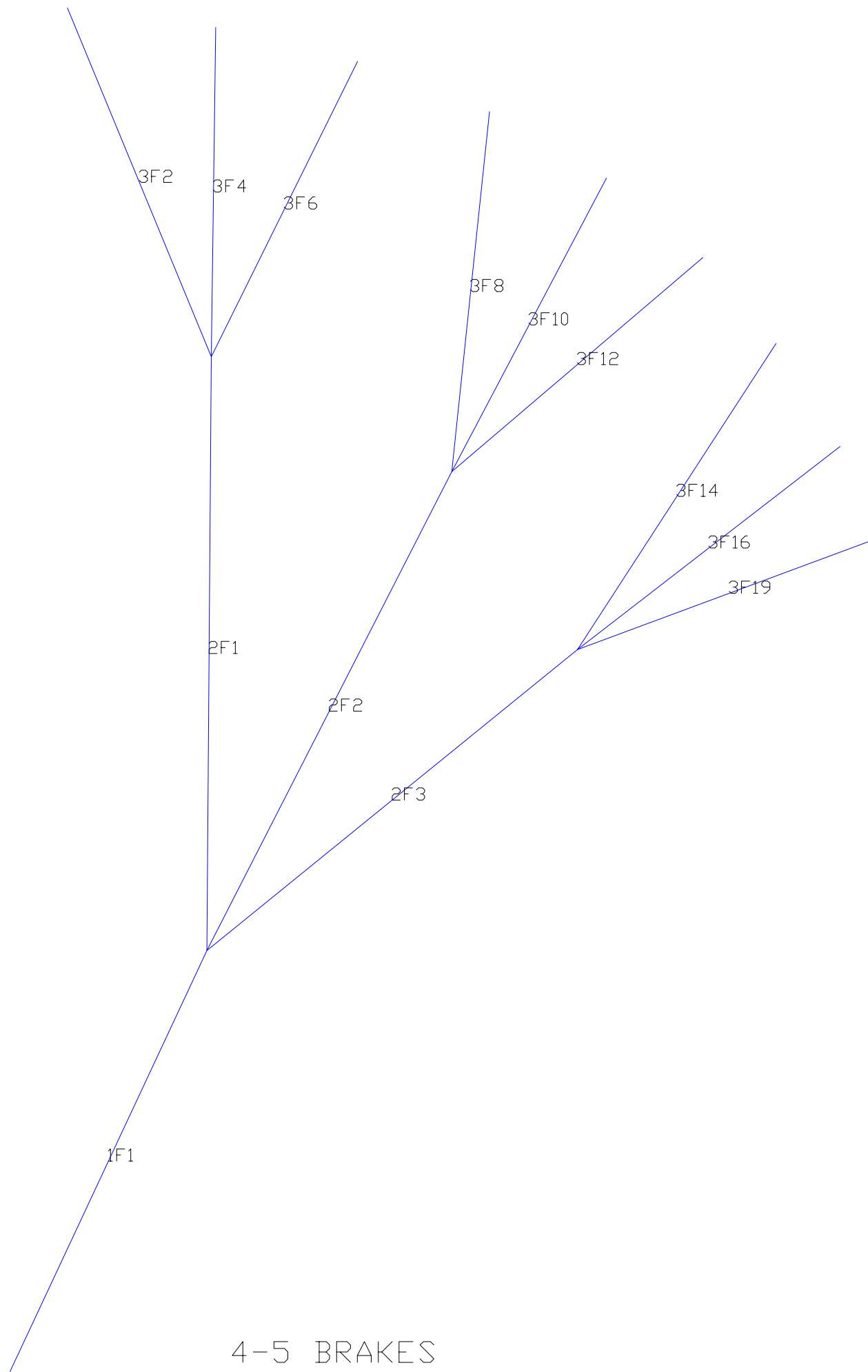

BRAKE_DISTRIBUTION
CENTER

0.00

0.00

0.00

0.00

WING_TIP

0.00

0.00

25.00

55.00

70.00

100.00

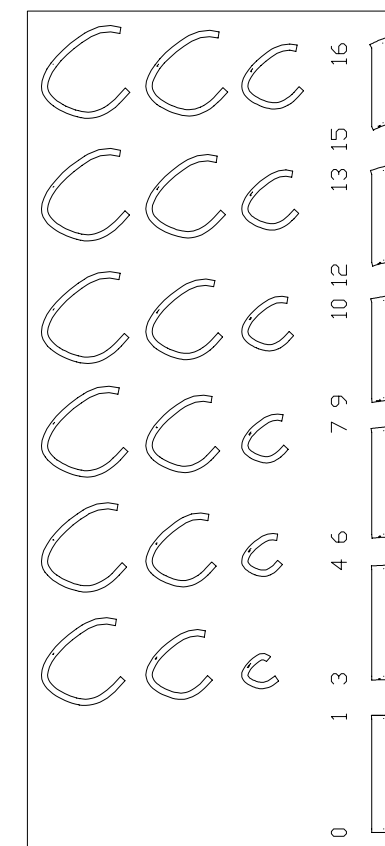
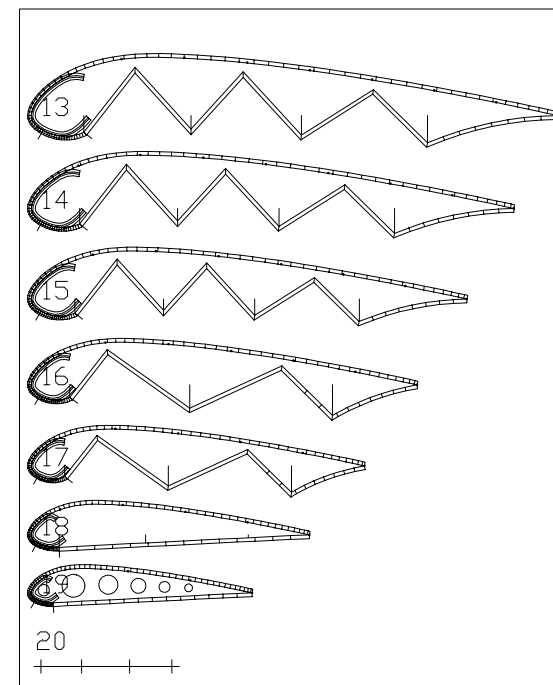
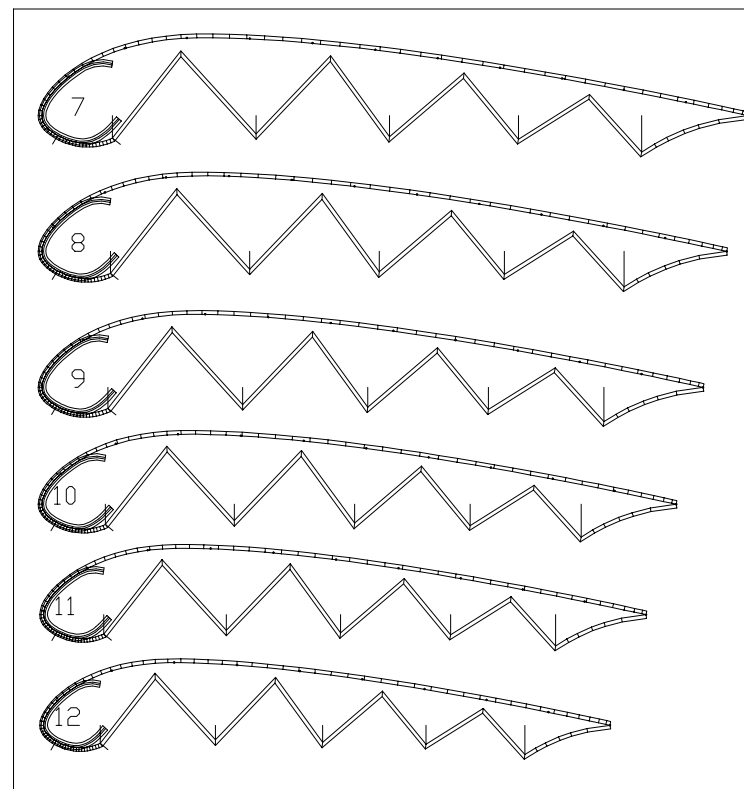
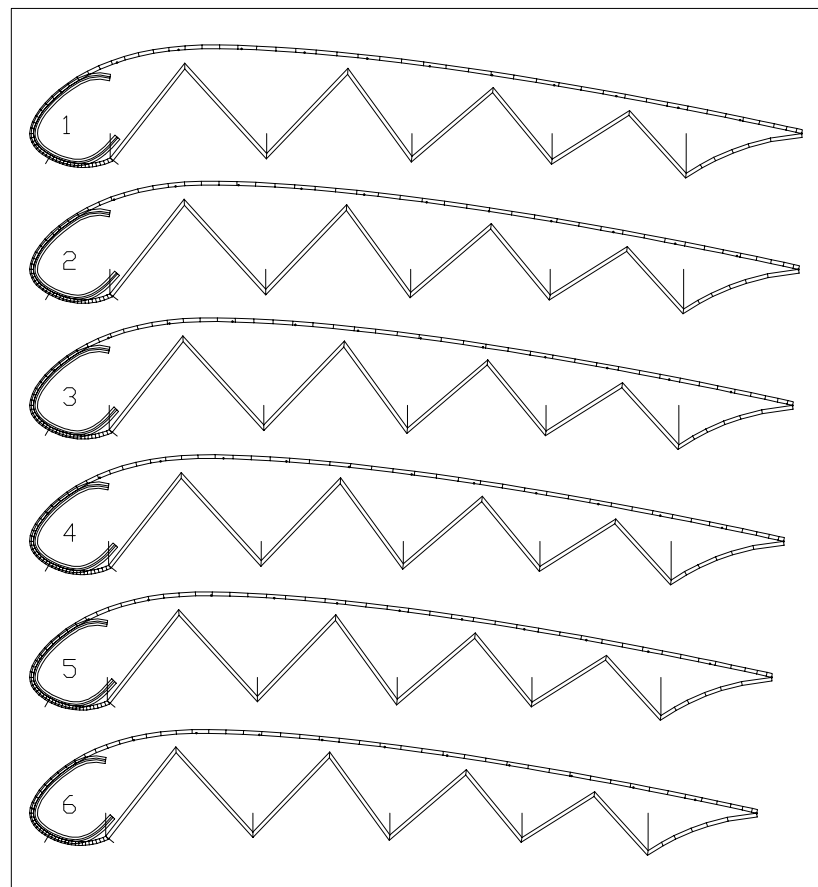

3-8 RIBS, POCKETS, AND HORIZONTAL STRAPS TO PRINT A4 (SCALE $\times 10$)

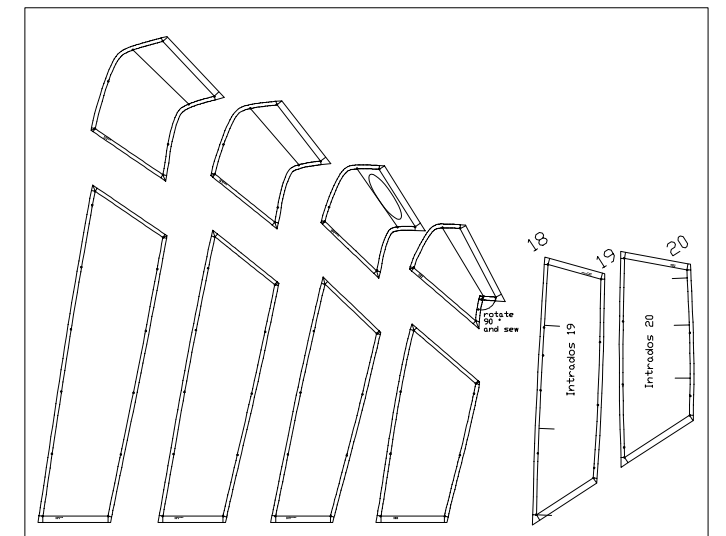
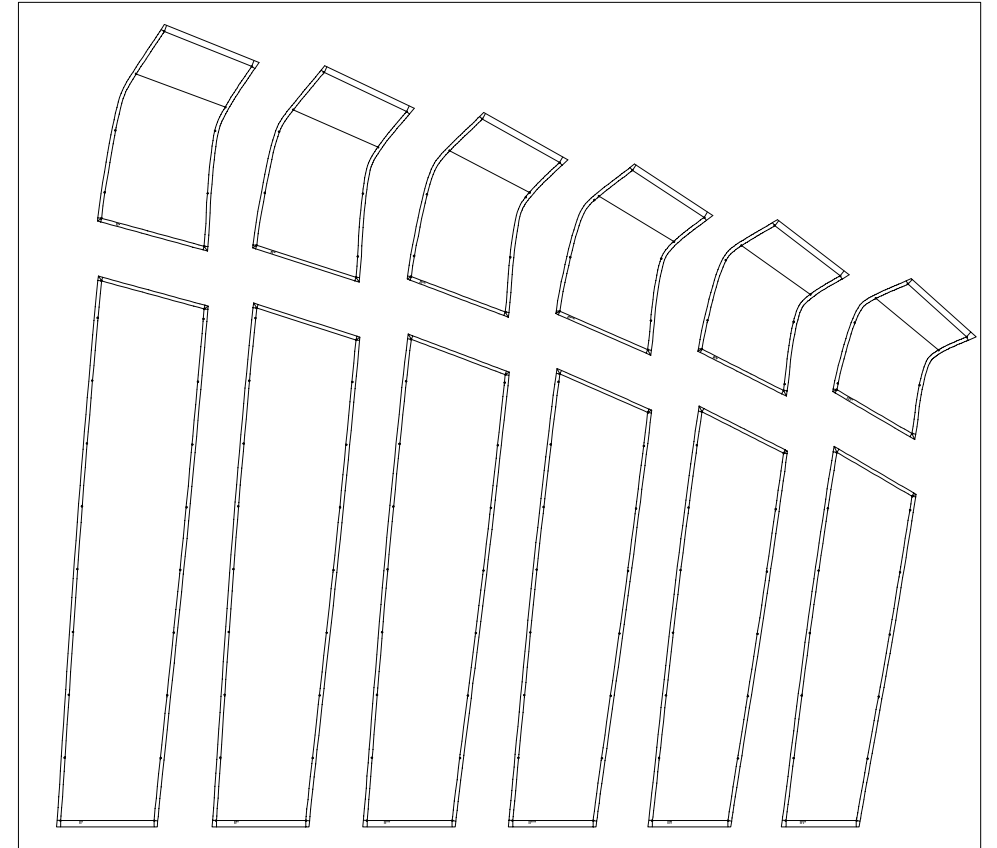
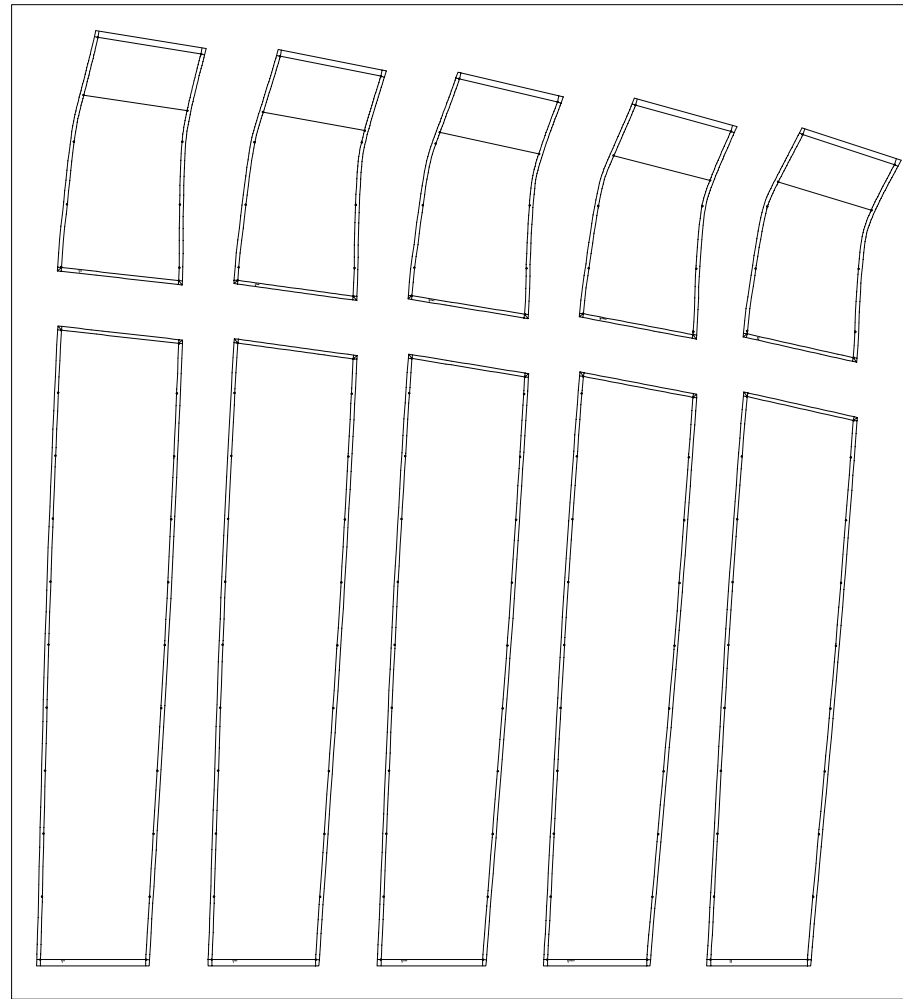
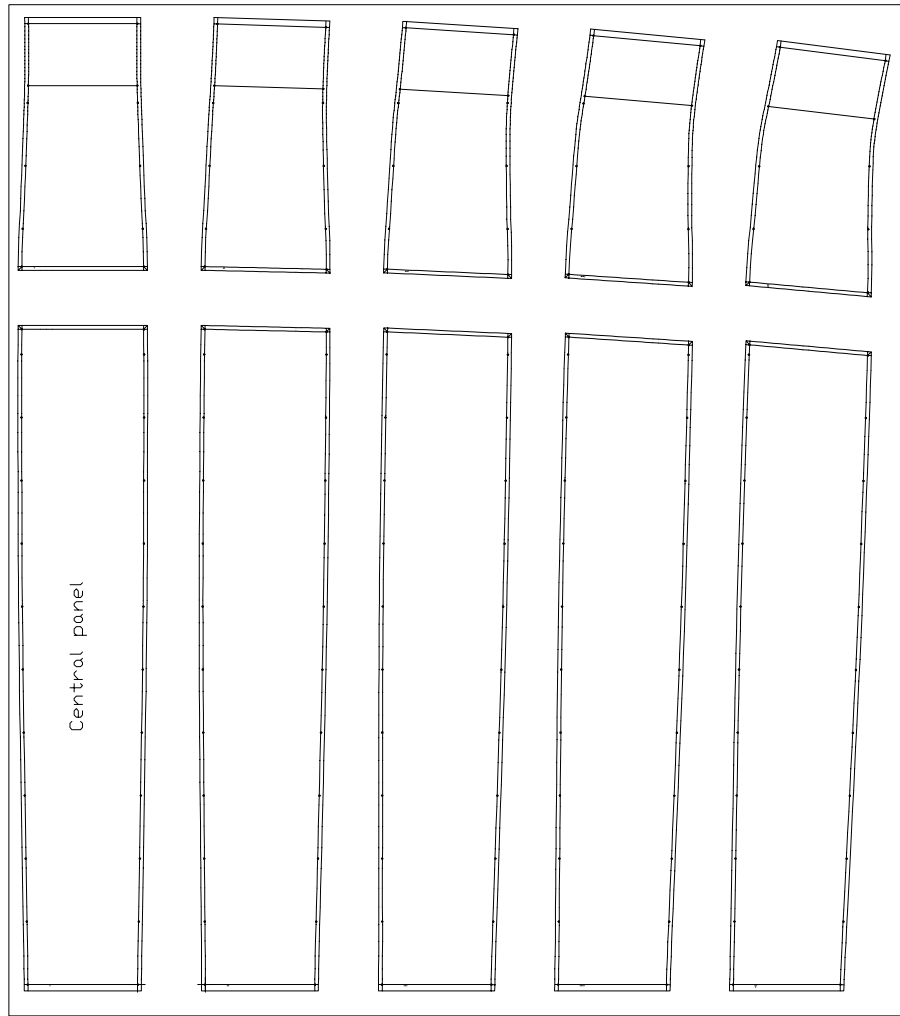

2-8 ALL PANELS TO PRINT IN A4 (SCALE $\times 10$)

PLANS GENERAL NOTES

- 1-1: Planform and vault view (informative)
- 1-2: Ribs for plotter, one side
- 1-3: Extradados panels for plotter, one side
- 1-4: Ribs for laser cutting, one side. Units cm
- 1-5: Extradados for laser cutting, one side. Units cm
- 1-6: Middle unloaded ribs for laser cutting, one side Units cm
- 1-7: Rods pockets and nylons lengths, mylars
- 1-8: Intermediate and ovalized airfoils

- 2-1: Calage estimation, speed and trim systems
- 2-2: Ribs printed with washin angle (informative)
- 2-3: Intrados panels for plotter, one side
- 2-4: Mini-ribs horizontal and diagonal
- 2-5: Intrados for laser cutting, one side
- 2-6: Full diagonal ribs laser, one side
- 2-8: All panels to print in A4 sheets (scale x10)

- 3-1: Upper view 3D (informative)
- 3-2: Lines A
- 3-3: Lines B
- 3-4: Lines C
- 3-5: Lines D
- 3-6: V-rib type-6
- 3-8: Ribs, pockets, and horizontal straps to print in A4 sheets (scale x10)

- 4-1: Vault view (informative)
- 4-2: Lateral view (informative)
- 4-3: Brake distribution (informative)
- 4-4: Free
- 4-5: Brake lines
- 4-6: Free
- 4-7: General notes

UNITS

Main units are centimeters. Scale x10 to use in mm

WIDTHS FOR SEWING AND OFFSETS

- Lateral width in extradados (mm): 15.00
- Width in leading edge ex (mm): 25.00
- Width in trailing edge ex (mm): 25.00
- Lateral width in intrados (mm): 15.00
- Width in leading edge in (mm): 25.00
- Width in trailing edge in (mm): 25.00
- Lateral width in ribs (mm): 15.00
- Lateral width in V-ribs (mm): 15.00
- General offset lateral points (mm): 1.20

- Distance between equidistant points (cm): 25.00

"ROMAN" NUMBERS CODIFICATION Numbering panels, ribs, mini-ribs, V-ribs

Number	1 =	...
Number	2 =	...
Number	3 =	...
Number	4 =	...
Number	5 =	...
Number	6 =	...
Number	7 =	...
Number	8 =	...
Number	9 =	...
Number	10 =	...
Number	11 =	...
Number	12 =	...
Number	13 =	...
Number	14 =	...
Number	15 =	...
Number	16 =	...
Number	17 =	...
Number	18 =	...
Number	19 =	...
Number	20 =	...

